

# New materials and technologies

R. PAMPUCH\*

Faculty of Materials Science and Ceramics, University of Science and Technology (AGH), 30 Mickiewicza Ave., 30-059 Cracow, Poland

**Abstract.** A short overview of the developments of functional materials featuring miniaturisation and integration is illustrated by examples taken from the field of ceramic functional materials. To obtain new materials new methods are required. Most of them are microfabrication processes developed by the “top-down” approach.

**Keywords:** microfabrication processes, biomimetic materials, smart materials and systems, materials for information storage and transmission.

## 1. Introduction

Advanced materials are conventionally divided into structural and functional ones. Development of the first group of materials has been characterised by an increase of phasal complexity, from single-phase materials over surface-modified materials to fibre re-inforced composites, laminates and functional gradient materials. A decrease of size of constituent grains and particles down to nanometers has been found to be sometimes advantageous. Development of functional materials has featured a miniaturisation of the components and their integration. In both cases the development has stemmed from known laws of physics and chemistry but owing to small size and specific shape of components the new materials may acquire properties which are not easily, if ever, attainable in classic materials.

The present short overview deals mainly with functional materials because their development is more dynamic than this is the case of structural materials. Researchers who are interested in basic problems find here still large areas of the unknown as a challenge. Another challenge for basic research is to approach nature with its perfect way to perform various functions. Strong driving forces exist in this field also for applied research namely, the changes in social life associated with introduction of information and telecommunication technologies, with smart houses and cars, with requirements of the health service a.s.o.

Because the field is a broad and quickly developing one it has been necessary to impose some restrictions on the content of the paper. In agreement with what has been said before the main stress has been put on materials/material systems mimicking nature and on materials for information technology. A further restriction has been a confinement to the fields of earlier presented research activity of the author, namely to ceramic materials. On the one hand, this should permit to convey rather certain and not misleading information in a field where the opposite is not rare. On the other hand, the rich variety of shapes and functions performed by ceramic materials per-

mits us to illustrate well the main lines of development of functional materials in general.

## 2. Nano and microfabrication methods

In the field of new functional materials there has been a need for new fabrication methods. One could divide them in nano- and microfabrication methods, according to the resolution of the smallest features of the products, equal to several nanometers and few micrometers, respectively. The new fabrication methods typically have put to use electronics and photonics and have been developed by the “top-down” approach, i.e. by a modification of methods used earlier for producing classic materials. Table 1 shows, after [1], some more important microfabrication methods for producing ceramic materials. The methods permit us to obtain objects of a resolution of their smallest elements ranging from a few to some hundreds of micrometers. Most of them deploy suspensions of ceramic powders (including nanopowders) in liquids, polymers, polymer solutions a.s.o. to make either final products or templates of a specific shape next filled with powders and powder suspensions. To more important methods belong variations of rapid prototyping (Fig. 1), such as printing with binder solutions and powder suspensions, respectively (Figs. 2 and 3), stereolithography (Fig. 4). A great potential for producing microobjects has the method called laminated object manufacturing (LOM) which uses ceramic green tapes (Fig. 5). The tapes are powder suspensions constituted by powder, binder, dispersing agent and solvent. Typical constituents of suspensions used in classic ceramic technology are described in [2]. The green tapes are used, e.g., in the LTCC process. In a classic form of the process, after stripping off a carrier tape, the tapes are divided in discrete parts by cutting, and are shaped by making vias, channels a.s.o. The parts are next stacked, laminated under pressure and, finally, sintered. Figure 6 shows, after [3], a typical product obtained by this method, a telecommunication micro-module constituted by several ceramic layers containing embedded passive elements such as resistors, conductive paths, induction coils a.s.o. One-dimensional (1D) nano- and micromaterials require specific fabrication methods.

---

\* e-mail: roman.pampuch@xl.wp.pl

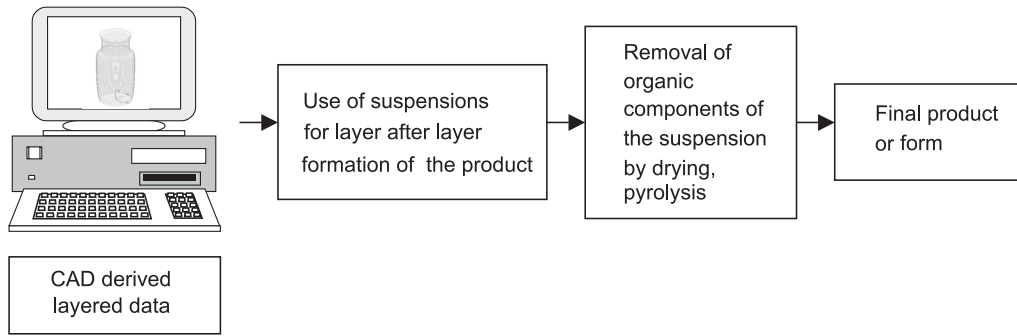

Fig. 1. Schema of rapid prototyping (for ceramic materials and templates)

Some of them shall be referred to in a proper context in Section 4.

Table 1

Microfabrication methods of ceramic materials

Method	Smallest feature resolution [ $\mu\text{m}$ ]	2D layers or 3D bodies
RP- micropen writing	250	3D
RP-ink-jet printing of binder solution (3DP process)	200	3D
RP-ink-jet printing of suspensions	100	2D
Screen printing	70–170	2D
Direct ceramic machining of presintered bodies	50	3D
LTCC	25–100	3D
Lithography, eg. LIGA	10–20	2D/3D
Microstereolithography	2	3D
Soft lithography	1–5	2D/3D

Remarks: LTCC – low-temperature co-fired ceramic multilayer technology; RP- rapid prototyping; LIGA- X-ray lithography (Litographie-Abformung-Galvanotechnik)

of such an approach is illustrated in Fig. 7. The idea has been partly realised in soft lithography [5] where elastomeric stamps are used to organise the structure of products.

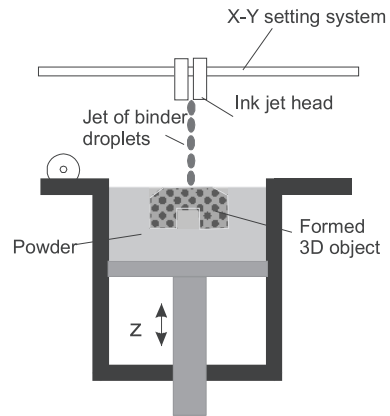

Fig. 3. Rapid prototyping; ink-jet printing of binder solutions (3DP process)

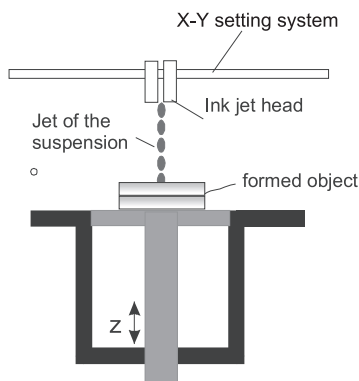

Fig. 2. Rapid prototyping; ink-jet printing of suspensions

In the future, technologies developed by the “bottom up” approach, should probably become equally important. These are the methods which utilise processes where replicating and self-organising nanostructures grow to larger, more or less complex, ones [4]. The general idea

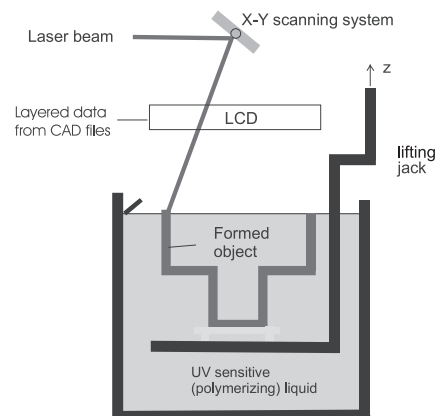

Fig. 4. Microstereolithography. The layered data from CAD successively displayed on the liquid crystal display serve as masks for the laser beam; the product (composed of ceramic powder with binder) is formed in a liquid polymerising under the action of laser radiation

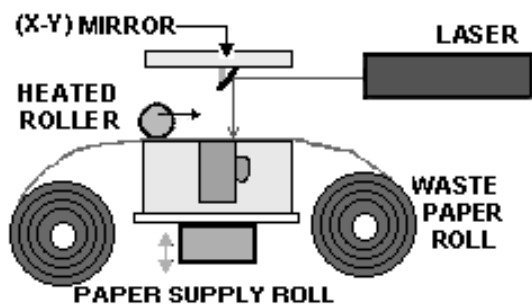

Fig. 5. Laminated object manufacturing; in case of ceramic materials the rolls of ceramic green tapes are used

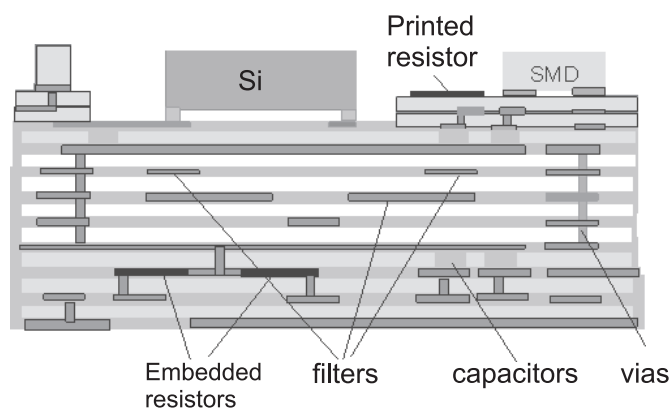

Fig. 6. Micromodule for telecommunication in the microwave and radio frequency range



molecular structure of the product



"sticky" template

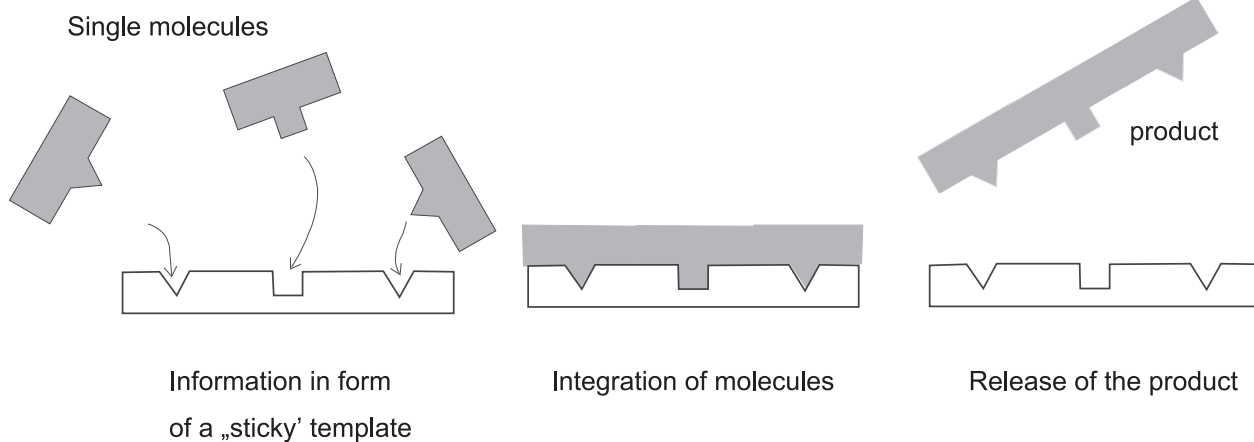

Fig. 7. The idea of self-replication in materials manufacturing; after [4]

### 3. Materials and systems mimicking nature

**3.1. Biomimetic materials.** Biomimetic materials constitute an obvious link to nature. Already the fibre reinforced composites and laminates mimic some features of the structure of organic systems performing mechanical functions, such as muscles and bone. The former may be described as a fibrous network while the hard bone consists of alternating layers of hydroxyapatite and of a soft organic issue. The mimicking can be accomplished to a limited extent only. Namely, the structure of organic systems is a hierarchical one which could not be

fully realised in synthetic composites until now [6]. Consequently, the properties of the latter do not approach the flexibility observed with organic systems.

Another direction is a transformation of natural objects to their pseudomorphoses by changing their chemical composition. Due to this the advantageous structure of natural objects is preserved but their resistance to high temperatures, aggressive environment a.s.o. may be increased. One of the better known examples are silicon carbide pseudomorphoses of wood (Fig. 8). The pseudomorphoses are obtained in a process which involves carbon pyrolysis, followed by reaction of the carbon residue with

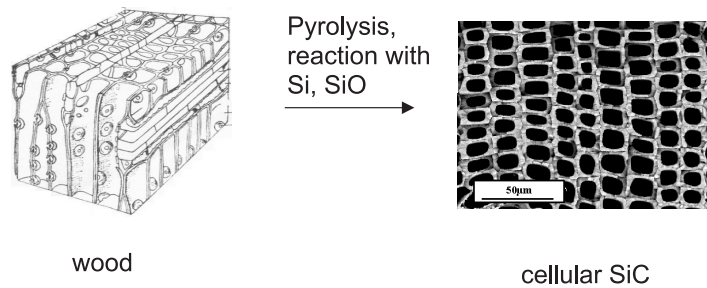

Fig. 8. Cellular silicon carbide produced by pyrolysis of wood and subsequent reaction of the carbon residue with silicon and/or SiO

gaseous or liquid silicon or gaseous SiO [7, 8]. Producing pseudomorphoses of natural objects may also help to lower production costs of complex ceramic shapes. Namely, conventional ceramic technology for complex shapes uses machining as a final step which is very expensive and time-consuming. If natural objects have an appropriate shape they may be transformed by reaction in useful ceramic components. An example purvey MgO pseudomorphoses of frustules (silicized walls of diatomite cells) which are obtained by reaction of the frustules with magnesium vapour at 900°C [9].

**3.2. Smart materials and systems.** Materials and systems are called smart when they have two basic ways in which living systems react to the environment. Namely, a recognition of the nature of the environment and an

adequate reaction to stimuli from the environment. In other words, the living systems play a role of both a sensor and an actuator. Such a behaviour may be mimicked by active smart systems, the schema of which is given in Fig. 9. The actuator and sensor usually form a feedback loop over a microprocessor. Information in the loop is transmitted by electrons. Tables 2 and 3 collect, respectively, the most commonly used sensors and actuators. In order to decrease the response time sensors, actuators and microprocessors have to be integrated. This has been realised in microelectromechanical systems (MEMS), an example of these systems being illustrated in Fig. 10. The MEMS are produced by using silicon chips submitted to combinations of lithography and etching.

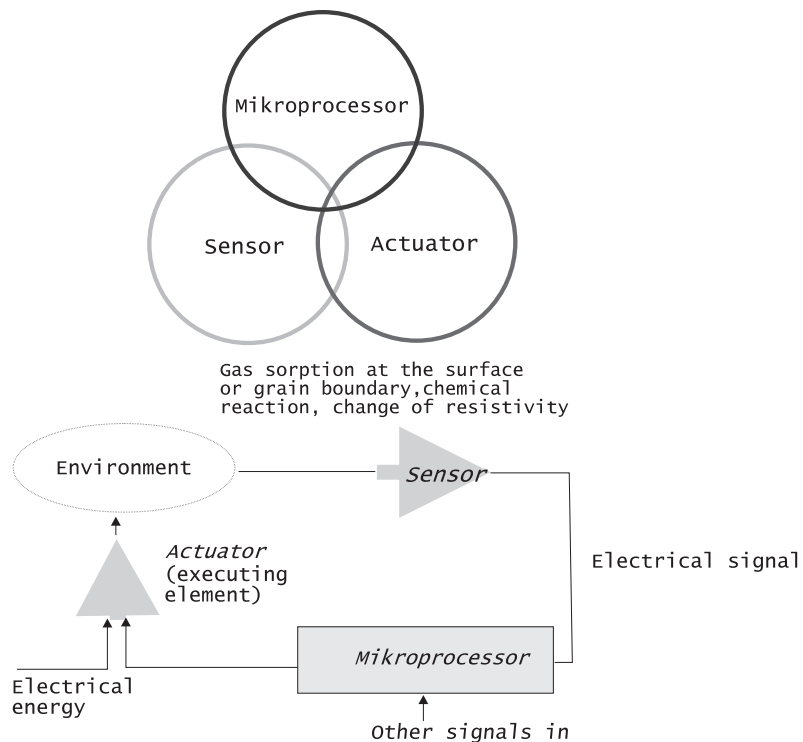

Fig. 9. Active smart systems and example of an active smart system for monitoring the chemical composition of gases

Table 2  
Currently used sensors

Exchanged energies	Effect utilised	Typical material	Some applications
Mechanical-electrical	Piezoelectric effect $\rho = f(\varepsilon)$	PZT	Sensors of position, of displacement
Mechanical-magnetic	Inverse magnetostrictive effect $B = f(\varepsilon)$	Fe, Co, Ni	Sensors of force, twist, displacement, deformation
Optical-electrical	Pyroelectric effect $E = f(Eh\nu)$	PLZT	Night vision devices, temperature sensors
Thermal-electrical	$\rho = f(T)$	AB <sub>2</sub> O <sub>4</sub> , BaTiO <sub>3</sub>	NTCR and PTCR sensors
Chemical-electrical	$\rho_{surf} = f$ (chemical reactions at the surface)	SnO <sub>2</sub>	Sensors of chemical composition of gases

Symbols used:  $\rho$  – resistivity;  $\rho_{surf}$  – surface resistivity;  $\varepsilon$  – deformation;  $B$  – magnetic induction;  $E$  – electric field intensity;  $E_{h\nu}$  – photon energy;  $T$  – temperature

Table 3  
Currently used actuators

Energies exchanged	Effect utilised	Typical material	Some applications
Electrical-mechanical	Converse piezoelectric effect; $\varepsilon = f(E)$	Pb(Zr <sub>1-x</sub> Ti <sub>x</sub> )O <sub>3</sub>	Actuators of position, of valves, of ink-jet heads
Magnetic-mechanical	Magnetostriction $\varepsilon = f(H)$	Fe, Co, Ni, Tb <sub>x</sub> Dy <sub>1-x</sub> Fe <sub>y</sub> , Ni <sub>2</sub> MnGa	Actuators of position, of shock absorbers, of fuel injection devices
Electrical-optical	$n = f(E)$	LiNbO <sub>3</sub>	Electrooptical modulators
Electrical-thermal	$E = Uit$ ; $\rho = f(T)$	SiC, Si <sub>3</sub> N <sub>4</sub> , AB <sub>2</sub> O <sub>4</sub> , BaTiO <sub>3</sub>	Heaters, NTCR and PTCR actuators
Electrical-chemical	$O^{2-} \rightarrow 1/2O_2(g) + 2e^-$ (at the electrode facing a lower O <sub>2</sub> concentration)	Concentration cells based on ZrO <sub>2</sub>	Oxygen pumps

Symbols used (see also Table 2):  $H$  – magnetic field strength;  $U$  – voltage;  $t$  – time

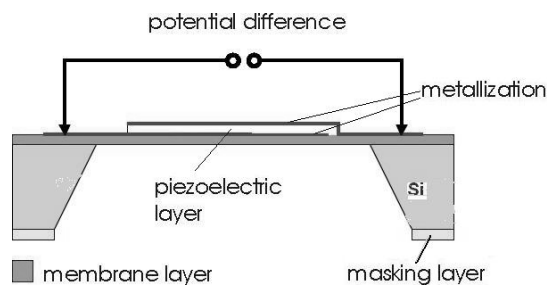

Fig. 10. An example of integrated micromechanical system – acting as a piezoelectric actuator

#### 4. Materials for information storage and transmission

Because of the role played by microprocessors in modern technology, also in development of new production methods, there is much interest in introducing new materials to increase the efficiency of information storage and transmission. An example of ceramic materials used in this field are thin ferroelectric layers for random access memories (Table 4).

Table 4  
Ferroelectric materials for information storage

Material	Mode of action	Effect
Ferroelectric random access memories (FeRAM)	Microcapacitors as cells; the states “0” and “1” of binary logic realised by changing the direction of spontaneous polarisation; recording by applying + and – voltage, respectively; reading by scanning free charges on the electrodes	Shortened access time
Ferroelectric memories made up of field effect transistors	One of the electrodes of a microcapacitor is constituted by a ferroelectric layer; this structure is utilised as the gate of the field effect transistor	Non-destructive read operation

Let us turn now to new ceramic materials for information transmission. Information can be transmitted by electrons, photons or chemical molecules. According to general trends, materials serving as the medium for transmitting information by these carriers should ensure a miniaturisation of devices. In particular, they should permit to localise and direct electrons, photons and molecules in small volumes of the order of nanometers and few micrometers (see Table 5).

Table 5  
Information carriers and materials serving for information transmission

Information carrier	Typical material	Mode of action
Electrons	Carbon nanotubes (SWCNT); Si, SiC, GaAs, InAs, ZnS, CdS, ZnO, MgO, SiO <sub>2</sub> , BaTiO <sub>3</sub> nanotubes	Localisation of electrons and restriction of their movement to the axis of the nanotubes (nanotubes are a quantum wire)
Photons	Photonic crystals (materials with an optical band gap), e.g. "holey" optical fibres	Localisation of photons and restriction of their movement to line defects in the photonic crystal structure
Gaseous and liquid molecules	Materials and devices for microfluidics	Mixing and distribution of fluxes of liquids and gases in microchannels of a diameter below 100 μm, allowing reactions and heat transfer

As far as electrons are concerned, the turning point has been the re-discovery of carbon nanotubes (as a side-effect of research into fullerenes). There are single-walled (SWCNT) and multi-walled (MWCNT) carbon nanotubes, having diameters between 0.7 to 2 nm and lengths up to 20 μm. The latter tubes have, as far as electrical properties are concerned, mixed properties while the former are either semiconductors or metallic conductors subject to their diameter. Due to their small diameter the carbon tubes act as quantum wires, i. e. localise the electrons inside the tubes and allow their transmission in the direction of the axis only. There are various current and potential applications of carbon nanotubes, such as miniature cathode ray-tubes, active elements and circuits in electronics. An example of the latter applications is a field-effect transistor where the carbon nanotube serves as the channel for electrons (Fig. 11) [10]. Nanowires and nanotubes of many other semiconductors, such as Si, GaAs, InP, ZnS, CdS, ZnO, BaTiO<sub>3</sub>, PbTiO<sub>3</sub>, have also been obtained and their possible applications perceived for construction of electronic and photonic devices of nanometric dimensions, for example laser diodes. It is thus reasonable to say that the 1D nanomaterials are the most important kind of nanomaterials.

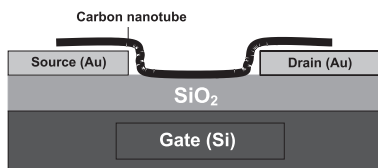

Fig. 11. Field effect transistor with carbon nanotubes serving as the channel for electrons

Further progress in information transmission depends upon the use of photons. For example, large-scale computing requires a concerted action of thousands of microprocessors which store together enormous amounts of data. In this situation a broad-band information exchange with negligible delays and losses are necessary. Such requirement can be met when photons substitute for electrons as information carriers. The materials which may enable us to achieve this goal are photonic crystals. The term photonic crystal, or, better, photonic quasi-crystal, denotes a material composed of at least two phases having different dielectric constants and thus different refractive indices. At least one of the phases has to form a 2D or 3D translational lattice with a lattice constant of the order of the length of light (near ultraviolet, visible, near infrared), i.e. from 1.10<sup>2</sup> to 1.10<sup>3</sup> nm (Fig. 12).

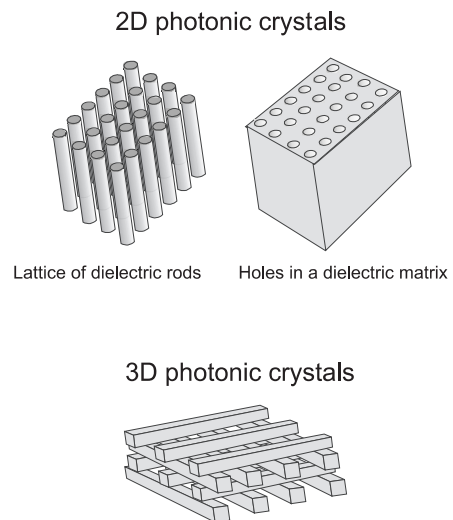

Fig. 12. Various kinds of photonic crystals (optical band gap materials)

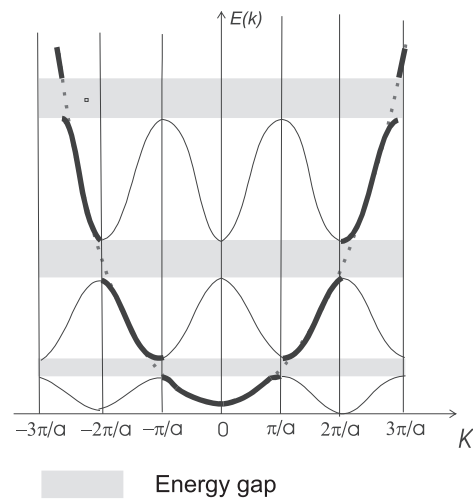

Fig. 13. The dispersion relation for electromagnetic waves interacting with a space lattice of material elements; a- the lattice constant of the material

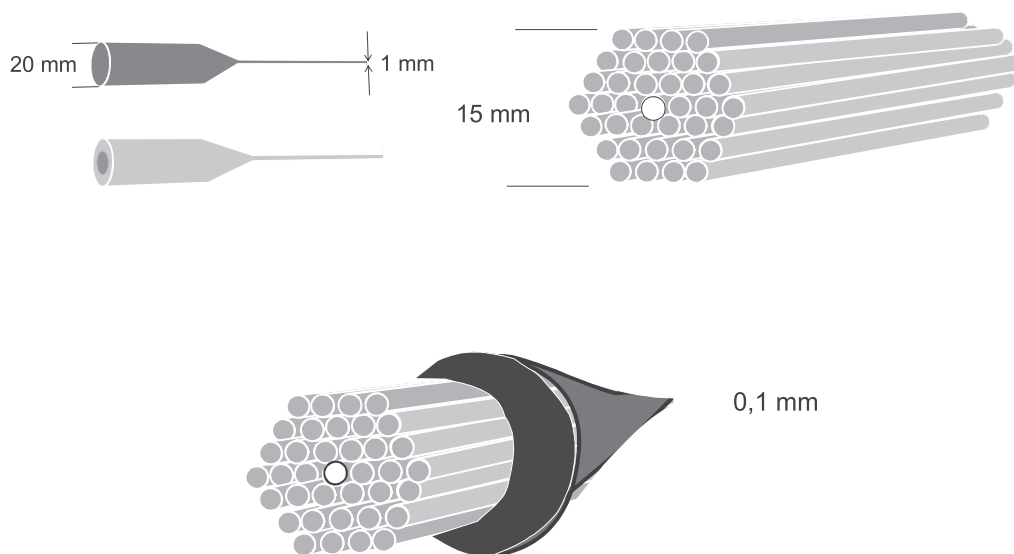

Fig. 14. Production of "holey" optical fibres by drawing of glass capillary tubes

An important type of photonic crystals are the so-called "holey" optical fibres, the cladding of which is a 2D photonic crystal (of the "holes in a matrix" type) extended in one direction. Because interaction with matter of any electromagnetic radiation obeys the same rules, there occurs in the photonic crystals an energy gap at certain optical frequencies of the UV, visible and IR range (Fig. 13). Specifically, there is a lack of allowed states of the transverse (electrical and magnetical) modes by which light is transmitted through the material. Light may, however, be transmitted via linear defects of photonic crystals. In case of the "holey" optical fibres such a defect is a hollow core in the fibre axis. In order to produce the "holey" fibres rows of glass capillary tubes are extended at elevated temperature what results in diminution of their diameter and in sticking of the extended capillary tubes together (Fig. 14). In the context of making miniaturised microprocessors based on photons it may be noted that photonic crystals in general and "holey fibres" in particular can transmit light without losses even when the light path changes by  $90^\circ$ . Such a situation is unavoidable in miniaturised microprocessors and not realisable even with modern conventional optical fibres.

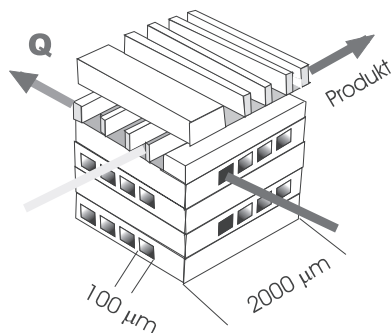

Fig. 15. Ceramic microreactor; the walls of the microchannels are covered by a catalyst

Transmission of information by molecules in miniaturised devices has a great potential in many fields, beginning with molecular biology, biotechnology and medicine and ending with microreactors. From DNA sequencing and drug administration to high-temperature catalysed reactions producing thousands tons of product yearly. Volumes of fluids (gases, liquids) from  $\mu\text{l}$  to pl are tackled here. Therefore, the whole field is called microfluidics.

Our discussion of this subject shall be limited to microreactors for high-temperature catalytic reactions (Fig. 15). Namely, ceramic materials are the obvious choice for such reactors owing to their thermal stability and resistance to aggressive environment. Typical microreactors are constituted by piles of thin plates containing microchannels about  $50\text{-}500\ \mu\text{m}$  deep and up to  $2000\ \mu\text{m}$  long, usually covered by a catalyst. The fluids flow from one layer to another undergoing mixing, heat exchange and reactions. The flow is laminar and characterised by Reynold's numbers  $< 100$ . Owing to this the resistance of flow is negligible while the large surface to volume ratio of the fluids diminishes also the thermal resistance. This ensures a good thermal control of the reactions. These factors are advantageous for a realisation of catalysed reactions between fluids in a short time and high yields. A carrying highly exothermic reactions out near the explosion point becomes also feasible. The small volumes handled permit also a relatively safe synthesis of poisons.

## REFERENCES

- [1] M. Heule, S. Vuillemin and L. J. Gauckler, "Powder-based meso- and microscale ceramic fabrication processes", *Adv. Materials* 15, 1237 (2003).
- [2] M. Szafran, "New trends in the formation of ceramic slip masses", in: "Commission works of ceramic sciences O/PAN in

Cracow", *Ceramics* 80, 62 (2003), (in Polish).

[3] N. Setter, "Electroceramics. Looking ahead", *Journal of the European Ceramic Society* 21, 1279 (2001).

[4] S. Węgrzyn et al., *Nano and Quantum Systems of Informatics*, ed. Silesian University of Technology, Gliwice, 2003.

[5] Y. Xia and G. M. Whitesides, "Soft lithography", *Angew. Chemie Int. Ed.* 37, 550 (1998).

[6] R. Pampuch, "Ceramic composites", *Composites* 2, 1 (2002), (in Polish).

[7] R. Pampuch, L. Stobierski, J. Lis and M. Rączka, "Solid

combustion synthesis of SiC", *Materials Res. Bull.* 22, 1225 (1987).

[8] P. Greil, P. Cromme and C. Zollfrank, "Biomorphous ceramics from cellulose templates", *Proceed. 8th Intern. Conference on Ceramic Processing and Technology*, Hamburg, 2002.

[9] K. H. Sandhage, F. M. Zalar, M. B. Dickerson, P. M. Huseman and M. E. A. Schoenwaelder, "Chemically-tailored 3D nanoparticle structures via the BaSIC process", *Proceed. 8th Intern. Conference on Ceramic Processing and Technology*, Hamburg, (2002).

[10] Information of the NEC Corporation (Japan) and IBM (USA) on the Internet, (2003) and (2004).